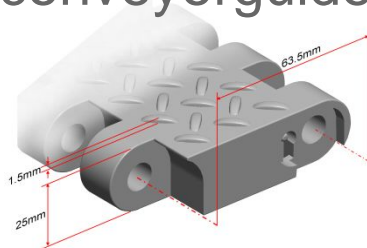

CONVEYOR GUIDE CO.,LTD.

บริษัท คอนเวเยอร์ไกด์ จำกัด

HS-1800D Technical Data Sheet

www.conveyorguide.co.th

Pitch: 63.5mm Minimum Width: 200mm Open Area: 0% Approved: FDA stainless steel Rod: Ø 10mm Flight: No Side Guard: No Curve: No	www.conveyorguide.co.th 
---	---

Data

Belt Material	Belt Strength Kg/M (BW)		Temperature		Belt Weight (Kg/M ²)
	Straight	Curve	°C (min.)	°C (max.)	
Acetal	10000	--	-40	80	33.3
Acetal+AS	10000	--	-40	85	33.3

BW – Belt Width AS - Flame retardant

Color Table

Polypropylene					Polyethylene					Acetal				
W	G	N	DB	B	W	G	N	DB	B	W	G	N	DB	B
										●			●	●

W-White, G-Gray, N-Nature, DB-Dark brown, B-Blue

Friction Table

Belt Material	Friction Wear strips & Products							
	UHMW	HDPE	Steel	Glass	SUS	Plastic	Cardboard	Aluminum
Polypropylene	0.32	0.24	0.15	0.09	0.13	0.08	0.15	0.25
Polyethylene	0.13	0.11	0.26	0.19	0.31	0.16	0.21	0.41
Acetal	0.11	0.09	0.27	0.16	0.26	0.15	0.19	0.28

SUS – Stainless Steel

Equivalent type with other Brand

Brand Name	Intralox	UNI	Rexnord	MCC	Easecon	Habasit	KVP	Regina
Series & Type	1800		2500			M6300		
			3120			M6400		

The above content is only for reference.

www.conveyorguide.co.th

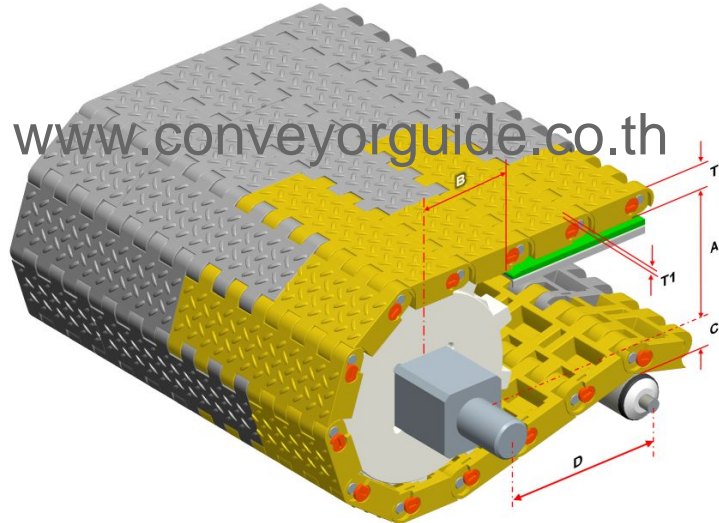

No. Teeth	A (Min.)	B (Min.)	C (Max.)	D (Min.)	T	T1
10	87.5	77	110	300	25	1.5
13	118	85	141	400		
15	138	92	162	500		
20	200	105	213	600		

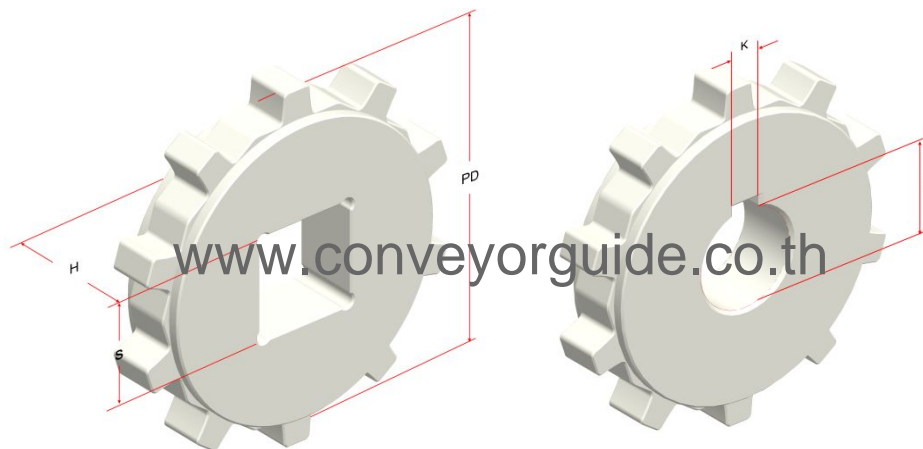

No. Teeth	PD	S	D	K	H
10	205	60.5	60.2	18X11	40
13	265	90.5	60.2	18X11	40
15	305	90.5	75.2	22X14	40
20	406	90.5	80.2	22X14	40

- The above sprockets are standard, and it also can be customized according to customer's request, including the teeth number of sprocket and the size of square bore; the processing time is about 2 weeks.